

Industrial electrical
equipment solutions

www.focquet.be

EUROPEAN
SPECIALIST
SINCE 1892



Squirrel cage asynchronous motor

HV HIGH VOLTAGE MOTORS

IP55

 Motors – rotating machinery



2EC



We transform and adapt motors and other equipment in order to fulfill specific requests.

About the company

Since its creation in 1892, our company has been offering a service in the broadest sense of the term.

As an SME operating in all sectors involving industrial electrical power equipment, we have been producing and delivering the equipment listed below without delay, for over 120 years.

- Asynchronous cage motors, low-power up to 1400kW

Four sectors are at the heart of our activities :

- Drive units and all types of electrical motors,
- Electrical transformers,
- Power electronics and
- Industrial pumps.

Who are we ?

Our activities within these different sectors revolve mainly around the buying, reconditioning, selling and renting of equipment.

Our considerable stock enables us to quickly meet your needs, with both new and second-hand equipment. Indeed, we have a wide range of both new electrical motors marked 2EC as well as second-hand motors.

In addition, our workshops allow us to provide excellent service when it comes to customising motors, thus meeting our clients' every need.



Motors products & services

- Asynchronous slip-ring motors, low-power up to 630kW
- Asynchronous cage motors, medium-power up to 1250kW
- Asynchronous cage motors, IP23, low-power up to 710kW
- Direct current motors, up to 800kW

A department specialising in pumps, including their repair, was created in 2005 and employs people who are highly experienced in this field.

In March 2011, we launched a new department called "Power Electronics".

In order to meet a growing demand for equipment with variable speed, we can now offer direct current variable speed drives of several kA in 2Q and 4Q, static variable frequency drives (low-power up to 3MW), as well as lowpower and medium-power soft starters.

CARACTÉRISTIQUES TECHNIQUES

Les moteurs FOCQUET 2EC sont conçus et fabriqués selon les normes IEC/EN 60034-1, IEC/EN 60034-2-1, IEC/EN 60034-30, IEC 60034-8, IEC 60034-12, IEC 60072, IEC/EN 60034-5, IEC/EN 600346, IEC/EN 60034-7, IEC/EN 60034-9, IEC 60034-14.

STRUCTURE

Les Motors MCHT sont fabriqués en Fonte. Notre système de refroidissement est conçu pour maintenir la meilleure température dans le moteur. Pour les moteurs 2 pôles et les basses vitesses, un ventilateur unidirectionnel sera préféré. Un ventilateur interne assure quant à lui une bonne répartition de l'échauffement.

La construction en cuivre des rotors et leur équilibrage de haute précision assure une réduction vibratoire au minimum des possibilités mécaniques. Tous les moteurs FOCQUET 2EC sont prévus pour un service S1 et leurs rendements se placent au meilleur de la norme en vigueur. Ils permettent d'économiser de l'énergie et de diminuer les coûts opérationnels.

GAMME DE TENSION

Une large gamme de tension de 3000 à 13800V est disponible pour 50Hz et 60Hz. N'hésitez pas à nous consulter.

PROTECTION ANTI-CORROSION

Les moteurs peuvent être utilisés dans des environnements sévères et agressifs, ils sont développés pour une utilisation longue et intense. Ils possèdent une protection effective contre la corrosion.

ROULEMENTS A CAPACITE DE CHARGE ELEVEE

En fonction de la charge et de l'application, les moteurs sont conçus avec des roulements billes / rouleaux ou paliers lisses afin d'assurer le meilleur maintien mécanique du process entraîné.

NIVEAU DE BRUIT

La gamme FOCQUET 2EC a été conçue pour minimiser le niveau sonore, en améliorant la conception des circuits magnétiques et électriques, la ventilation et la technologie de structure.

PROTECTION DES BOBINAGES

Des thermistances PTC sont en standard sur nos moteurs. Des résistances de réchauffage, sondes Pt100 et bien d'autres accessoires sont disponibles sur demande.

TEFC – IP55

Conçu pour des applications sévères, fabriqué avec des qualités de fonte utilisables dans tous types d'environnements. Le moteur est mécaniquement très robuste, il est aussi en standard utilisable avec un variateur de fréquence pour des gains supplémentaires d'énergie.

FLEXIBILITE DE CABLAGE

Afin d'assurer le plus de facilité dans le raccordement électrique de nos moteurs, la boîte à bornes de puissance peut être placée sur chacun des côtés du moteur et est orientable en fonction de l'arrivée des câbles.

VERSATILITE DE LA GAMME

Les Moteurs conviennent à une large gamme d'applications et d'environnements. Ils peuvent disposer d'options telles que : protection renforcée, isolation de classe supérieure, système de graissage, bague d'étanchéité, capot parapluie ...

TECHNICAL CHARACTERISTICS

FOCQUET 2EC motors are designed and manufactured according to the standards IEC/EN 60034-1, IEC/EN 60034-2-1, IEC/EN 60034-30, IEC 60034-8, IEC 60034-12, IEC 60072, IEC/EN 60034-5, IEC/EN 60034-6, IEC/EN 60034-7, IEC/EN 600349, IEC 60034-14.

STRUCTURE

The Frame of the MCHT motors is Cast Iron. Our cooling's design is made of two independent cooling systems. The outside fan and the inner fan assume the good temperature of the motor. For 2 poles motors and low speeds, single rotation fan is preferred to assume the correct cooling air flow.

The construction of our rotor is made of copper. High Precision balancing is the first step to reduce vibrations. All FOCQUET 2EC motors are built for S1 service and comply with the best efficiency Class of the actual standard, saving energy and reducing operating costs.

VOLTAGE RANGE

A wide range of voltages from 3000V up to 13800V is available for 50Hz and 60Hz. Do not hesitate to consult us for more details.

ANTI-CORROSION PROTECTION

The motors can be used in severe and aggressive environments as they have been developed for long and intensive use. They have effective protection against corrosion.

HIGH LOAD CAPACITY BEARINGS

Regarding the application and the load of the driven machine, our motors are designed with dedicated ball/roller or sleeve bearings in order to assume the best mechanical synergy with the driven process.

NOISE LEVELS

The FOCQUET 2EC range has been designed to minimize noise levels by improving the design of the magnetic and electrical circuits, ventilation and structure technology.

WINDING PROTECTION

PTC sensors are factory fitted on our motors. Space heaters, Pt100 sensors and a lot of accessories are available on request.

TEFC – IP55

Designed for severe applications and manufactured using cast steel that can be used in all types of environments. The motor is mechanically very robust and can be used as standard with a frequency regulator for increased energy output.

FLEXIBILITY FOR WIRING

Our terminal box can be placed on each side of the motor and can be rotated in order to facilitate the power cabling.

VERSATILITY OF THE RANGE

The Motors are suitable for a wide range of applications and environments. They can have options such as: increased protection, higher insulation class, lubrication system, sealing ring, rain canopy etc...

ROULEMENTS

BEARINGS

B3				
Frame Size	Driving End		Non-driving End	
	2(pole)	4.6.8.(pole)	2(pole)	4.6.8.(pole)
315	6317C3	6319C3/NU319	6317C3	6319C3
355	6317C3	6322C3/NU322	6317C3	6320C3
400	6319C3	6326C3/NU326	6319C3	6326C3
450	6220C3	6328C3/NU328	6220C3	6328C3
500		6330C3/NU330		6330C3
560		6334C3/NU334		6330C3

V1				
Frame size	Driving End		Non-driving End	
	2(pole)	4.6.8.(pole)	2(pole)	4.6.8.(pole)
315	6317C3	6319C3/NU319	7317	7319
355	6319C3	6322C3/NU322	7319	7322
400	6319C3	6326C3/NU326	7319	7326
450	6320C3	6328C3/NU328	7320	7328
500		6330C3/NU330		7330
560		6334C3/NU334		7330

ISOLATION ET CLASSE D'ÉCHAUFFEMENT

Les isolants sont, d'après IEC85, répartis en différentes classes. Pour chacune de ces classes est définie une température. Celle-ci fixe la limite supérieure du domaine d'emploi des isolants de la classe considérée leur garantissant une durée de vie acceptable dans les conditions normales de service. Un dépassement de cette limite de 8 à 10K réduira de moitié à peu près la durée de vie des isolants.

L'isolation de l'enroulement d'un moteur fixe l'échauffement aux points les plus chauds de ce dernier par rapport à la température ambiante à 40°C maximum.

En cas de fonctionnement à une température ambiante supérieure, la puissance nominale d'utilisation doit être réduite. Les moteurs FOCQUET **2EC** sont isolés classe F avec un échauffement limité à la classe B, ce qui leur confère une réserve thermique d'environ 25%. Si un échauffement correspondant à la classe F est autorisé, les puissances énoncées dans les tableaux peuvent être augmentés de 12%.

INSULATION AND WARMING CLASS

Insulation is divided into different classes according to IEC85. A temperature is defined for each of these classes. This sets the upper limit of the operating range for the insulators in the class concerned, guaranteeing an acceptable lifespan under normal operating conditions. Exceeding these limits by 8 to 10K will reduce by almost half the life of the insulation.

The insulation of the motor winding sets the heating at the hottest points of the motor compared to the ambient temperature with a maximum of 40°C.

In the case of operating at a higher ambient temperature, the nominal operating power rating must be reduced. FOCQUET **2EC** motors have Class F insulation with heating limited to Class B, which gives them a thermal reserve of around 25%. If heating to Class F is allowed, the power ratings given in the tables can be increased by 12%.

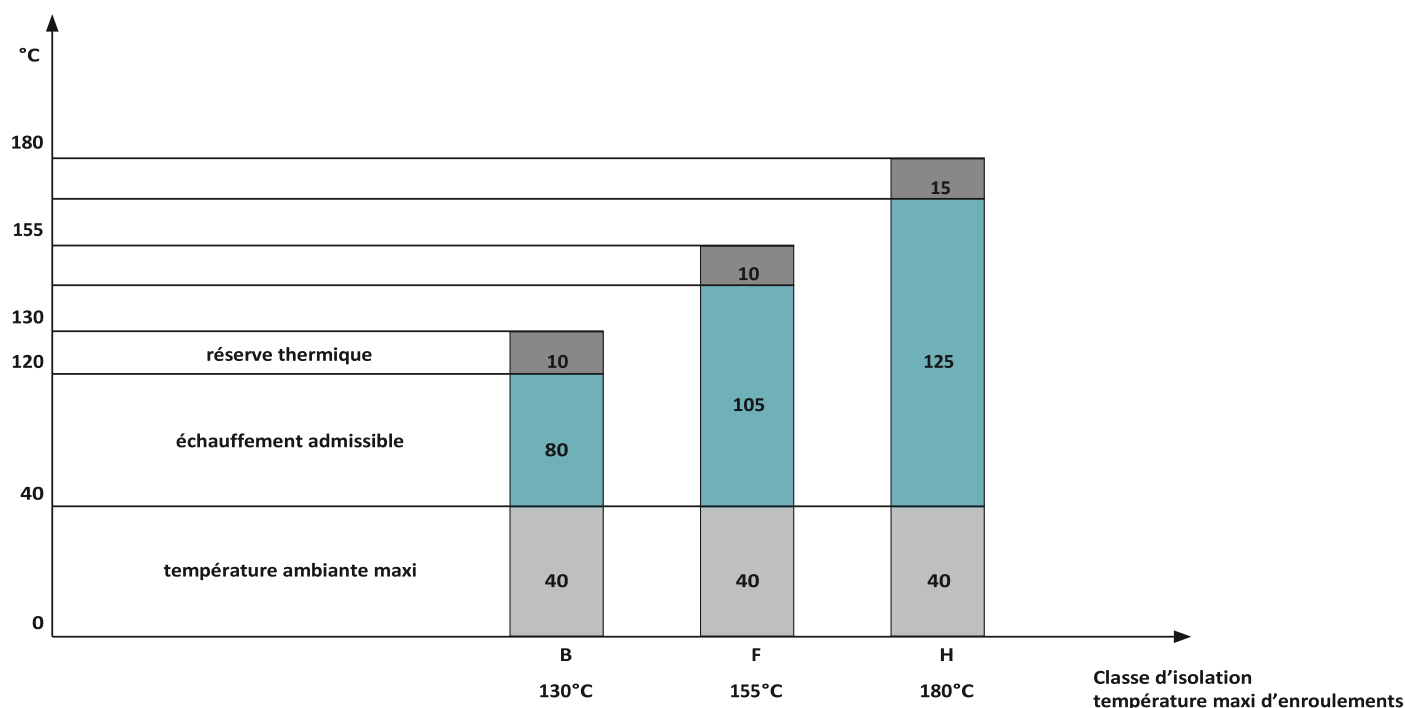

DESIGN ET OPTIONS

Afin de répondre au mieux à votre cahier des charges, nos moteurs sont capables de s'adapter à toutes les situations :

Boîte à Bornes

Ci-dessous un exemple de boîte à bornes pour le raccordement haute tension.

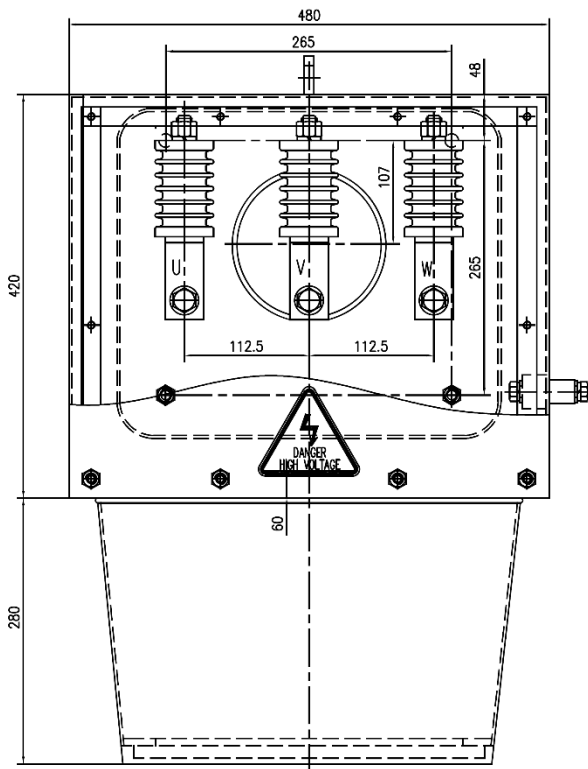

DESIGN AND OPTIONS

In order to fulfill your requirements the best we can, our motors are able to support all the situations:

Main Terminal Box

Below an example of a main terminal box for high voltage .

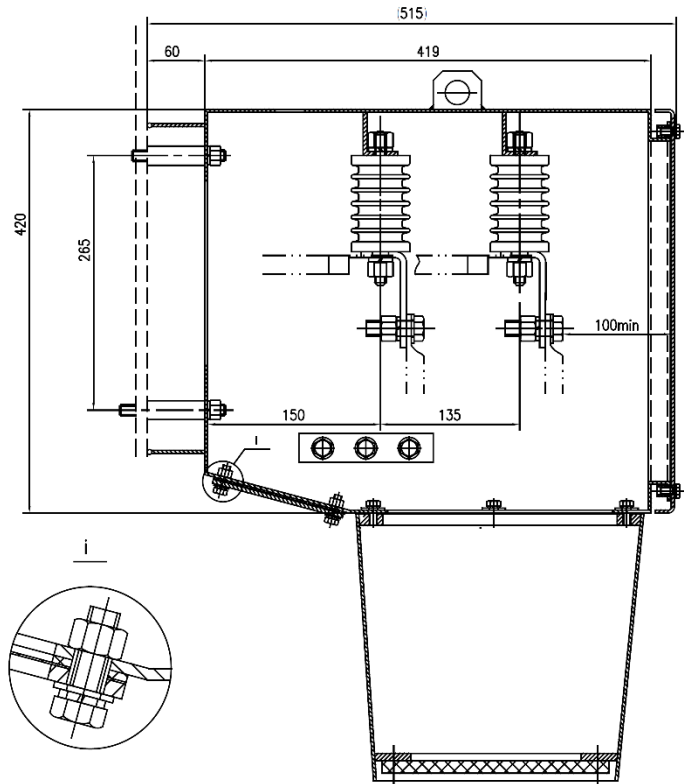

Boîte de Point Neutre (Option)

Nous pouvons ajouter une boîte de Neutre si vous le souhaitez .

Star Point Terminal box (Option)

We can add a Star point Terminal box if you need it.

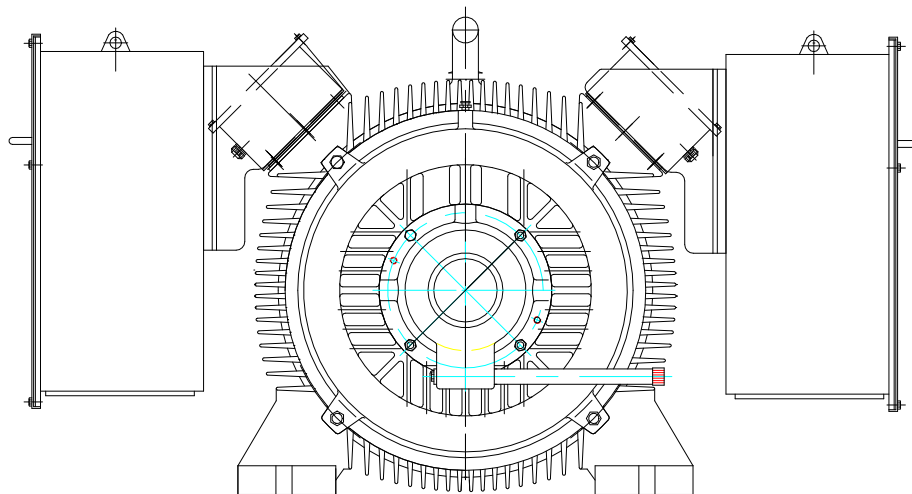

DESIGN ET OPTIONS

Boîtes Auxiliaires (Option)

Une Boite à bornes auxiliaire peut être ajoutée pour le raccordement des sondes de températures et les résistances de réchauffage.

Ci-dessous un exemple des options que nous pouvons ajouter.

DESIGN AND OPTIONS

Auxiliary terminal boxes (Option)

An auxiliary terminal box can be used for wiring temperature sensors and heating elements.

Below an example of the several options we can add in our motors.

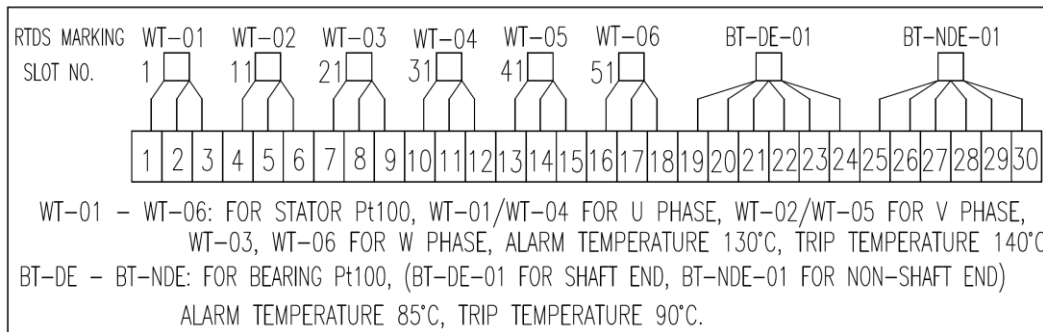
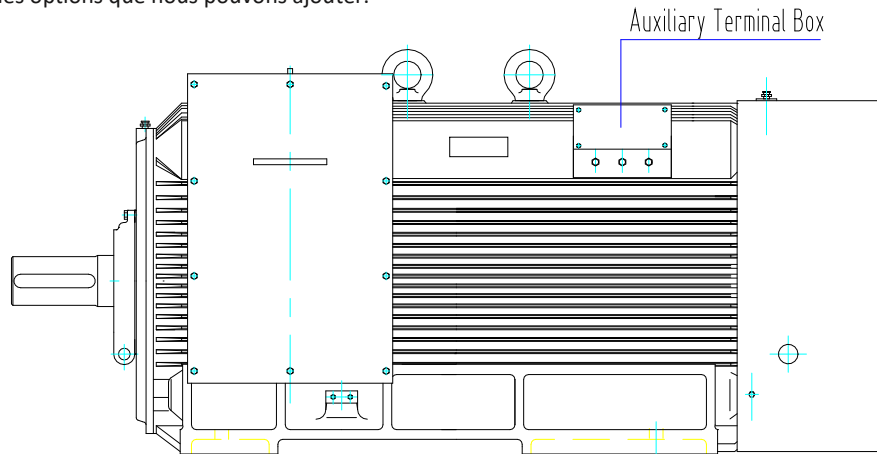

Autres

De nombreuses autres options sont disponibles, n'hésitez pas à nous consulter pour plus de détails.

Other

A lot of other options are available. Do not hesitate to consult us for more details.

DÉCLASSEMENT

DERATING

Ambient temperature	Altitude						
	1000	1500	2000	2500	3000	3500	4000
10°C	1.16	1.13	1.11	1.08	1.04	1.01	0.97
15°C	1.13	1.11	1.08	1.06	1.02	0.98	0.94
20°C	1.11	1.08	1.06	1.03	1.00	0.95	0.91
25°C	1.08	1.06	1.03	1.00	0.95	0.93	0.89
30°C	1.06	1.03	1.00	0.96	0.92	0.90	0.86
35°C	1.03	1.00	0.95	0.93	0.90	0.88	0.84
40°C	1.00	0.97	0.94	0.90	0.86	0.82	0.80
45°C	0.95	0.92	0.90	0.88	0.85	0.82	0.78
50°C	0.92	0.90	0.87	0.85	0.82	0.80	0.77
55°C	0.88	0.85	0.83	0.81	0.78	0.76	0.73
60°C	0.83	0.82	0.80	0.77	0.75	0.73	0.70

Les puissances moteurs de ce catalogue sont données pour une utilisation à température ambiante de +40°C et 1000m d'altitude. Dans le cas d'une utilisation d'un moteur à une température ambiante ou une altitude différente, il faut multiplier la puissance moteur par le coefficient du tableau ci-dessus.

Exemple:

Pour un moteur d'une puissance de 220kW à une température ambiante de 45°C et une altitude de 2000mètres. La puissance du moteur sera donc:

$$P=220kW \times \text{coef } 0,90 = 198kW$$

The motor's powers in this catalog are given to use at an ambient temperature of +40°C and 1000 m altitude. In case of a different ambient temperature or altitude, it's necessary to multiply the power motor by the coefficient given in the table above.

Example:

For a motor with a power of 220kW at an ambient temperature of 45°C and an altitude of 2000m. The power of the motor will be:

$$P=220kW \times \text{coef } 0,90 = 198kW$$

6kV -IP55 3000RPM/2P

Motor Type	Rated Power	Current	Sync Speed	Efficiency	Power Factor	Locked Current	Locked Torque	Maximum Torque	Moment of inertia	Weight
	kW	A	r/min	$\eta\%$	$\cos \phi$	Rated Current	Rated Torque	Rated Torque	J kgm ²	kg
MCHT220F2-315	220	25.2	3000	94.4	0.89	6.2	0.61	2.9	2.1	2865
MCHT250F2-315	250	28.6	3000	94.5	0.89	6.3	0.64	2.9	2.4	2900
MCHT280F2-315	280	31.6	3000	94.6	0.9	6.7	0.66	2.9	2.7	2950
MCHT315F2-315	315	35.6	3000	94.7	0.9	7.3	0.7	3.2	3.1	3040
MCHT355F2-355	355	40	3000	94.8	0.9	6.8	0.7	3	3.3	3075
MCHT400F2-355	400	45	3000	95.1	0.9	6.7	0.68	2.9	3.5	3160
MCHT450F2-355	450	50	3000	95.2	0.91	6.6	0.7	2.8	3.7	3215
MCHT500F2-355	500	55.5	3000	95.3	0.91	6.6	0.72	2.8	4	3280
MCHT500F2-400	500	55.9	3000	95.4	0.9	6.1	0.6	2.8	4.3	3230
MCHT560F2-400	560	62	3000	95.5	0.91	6.3	0.64	2.8	4.5	3700
MCHT630F2-400	630	69.7	3000	95.6	0.91	6.5	0.69	2.9	4.9	3820
MCHT710F2-400	710	78.5	3000	95.7	0.91	7	0.77	3	5.3	3950
MCHT800F2-450	800	89.3	3000	95.8	0.9	6.3	0.61	2.8	6	4700
MCHT900F2-450	900	100.4	3000	95.9	0.9	7	0.71	3	6.2	4800
MCHT1000F2-450	1000	111.3	3000	96.1	0.9	6	0.61	2.5	6.8	5000
MCHT1120F2-450	1120	123.1	3000	96.2	0.91	6.8	0.74	2.8	7.5	5100
MCHT1250F2-500	1250	137.3	3000	96.3	0.91	6.6	0.6	2.9	15	6860
MCHT1400F2-500	1400	153.6	3000	96.4	0.91	6.8	0.63	2.9	16	7000
MCHT1600F2-500	1600	175.3	3000	96.5	0.91	6.9	0.67	2.9	17	7140
MCHT1800F2-500	1800	197	3000	96.6	0.91	7.4	0.75	3	19	7400
MCHT2000F2-560	2000	218.7	3000	96.7	0.91	6.4	0.6	2.7	28	7800
MCHT2240F2-560	2240	244.7	3000	96.8	0.91	7	0.67	2.9	30	8030
MCHT2500F2-560	2500	272.8	3000	96.9	0.91	7.6	0.8	3	32	8300

Motor Type	Rated Power	Current	Sync Speed	Efficiency	Power Factor	Locked Current	Locked Torque	Maximum Torque	Moment of inertia	Weight
	kW	A	r/min	$\eta\%$	$\cos \phi$	Rated Current	Rated Torque	Rated Torque	J kgm ²	kg
MCHT220F4-315	220	25.5	1500	94.4	0.88	5.2	0.74	2.2	4.2	2900
MCHT250F4-315	250	28.9	1500	94.5	0.88	5.1	0.74	2.2	4.9	2970
MCHT280F4-315	280	32.4	1500	94.6	0.88	5.4	0.83	2.3	5.6	3050
MCHT315F4-315	315	36.3	1500	94.8	0.88	5.9	0.95	2.4	6.3	3120
MCHT355F4-355	355	40.9	1500	95	0.88	6.4	0.96	2.4	6.5	3220
MCHT400F4-355	400	46	1500	95.1	0.88	6.3	0.96	2.3	6.8	3290
MCHT450F4-355	450	51.1	1500	95.2	0.89	6.2	0.9	2.2	7.1	3340
MCHT500F4-355	500	56.7	1500	95.3	0.89	6.2	0.99	2.2	7.4	3400
MCHT500F4-400	500	56.7	1500	95.3	0.89	6	0.86	2.4	8	3970
MCHT560F4-400	560	63.5	1500	95.4	0.89	6	0.88	2.4	8.5	4080
MCHT630F4-400	630	71.3	1500	95.5	0.89	6.1	0.92	2.4	9.3	4170
MCHT710F4-400	710	79.4	1500	95.6	0.9	6.2	0.97	2.3	9.8	4250
MCHT800F4-450	800	89.4	1500	95.7	0.9	6.1	0.69	2.5	13	5000
MCHT900F4-450	900	100.4	1500	95.8	0.9	6.4	0.75	2.5	15	5200
MCHT1000F4-450	1000	111.5	1500	95.9	0.9	6.8	0.82	2.7	16	5450
MCHT1120F4-450	1120	124.7	1500	96	0.9	6.5	0.79	2.5	18	5700
MCHT1250F4-500	1250	137.5	1500	96.1	0.91	6.2	0.7	2.6	33	6850
MCHT1400F4-500	1400	153.9	1500	96.2	0.91	6.2	0.7	2.6	35	7040
MCHT1600F4-500	1600	175.7	1500	96.3	0.91	6.4	0.72	2.5	37	7180
MCHT1800F4-500	1800	197.2	1500	96.5	0.91	6.8	0.79	2.6	39	7330
MCHT2000F4-560	2000	218.7	1500	96.7	0.91	6	0.64	2.4	63	8170
MCHT2240F4-560	2240	244.7	1500	96.8	0.91	6.5	0.73	2.6	68	8420
MCHT2500F4-560	2500	272.8	1500	96.9	0.91	6.4	0.72	2.5	76	8660

6kV -IP55 1000RPM/6P

Motor Type	Rated Power	Current	Sync Speed	Efficiency	Power Factor	Locked Current	Locked Torque	Maximum Torque	Moment of inertia	Weight
	kW	A	r/min	$\eta\%$	$\cos \phi$	Rated Current	Rated Torque	Rated Torque	J kgm2	kg
MCHT185F6-315	185	22.2	1000	94.2	0.85	5	0.9	2.2	6.8	2670
MCHT200F6-315	200	24	1000	94.3	0.85	5.4	1	2.3	7.4	2720
MCHT220F6-315	220	26.4	1000	94.4	0.85	5.6	1.1	2.3	7.9	2850
MCHT250F6-315	250	29.9	1000	94.6	0.85	5.8	1.2	2.4	8.4	3000
MCHT250F6-355	250	29.9	1000	94.7	0.85	4.6	0.8	1.9	8.7	3255
MCHT280F6-355	280	33.4	1000	94.8	0.85	4.9	0.9	2	9.2	3345
MCHT315F6-355	315	37.6	1000	94.9	0.85	5.8	1.1	2.1	9.6	3440
MCHT355F6-355	355	42.3	1000	95.1	0.85	5.8	1.2	2.2	10.4	3530
MCHT400F6-400	400	47.6	1000	95.1	0.85	6.2	1.1	2.4	11.8	4010
MCHT450F6-400	450	53.5	1000	95.3	0.85	6.1	1.1	2.3	12.5	4110
MCHT500F6-400	500	58.6	1000	95.4	0.86	5.9	1.1	2.2	13.3	4200
MCHT560F6-400	560	65.5	1000	95.5	0.86	5.9	1.1	2.2	14.2	4290
MCHT630F6-450	630	73.7	1000	95.6	0.86	5.2	0.9	2	16	5100
MCHT710F6-450	710	83.1	1000	95.7	0.86	5.3	0.9	1.9	18	5300
MCHT800F6-450	800	93.4	1000	95.8	0.86	5.5	1	2	20	5500
MCHT900F6-450	900	105	1000	95.9	0.86	6	1.1	2.1	22	5700
MCHT1000F6-500	1000	116.6	1000	96	0.86	6.2	1.1	2.1	44	6820
MCHT1120F6-500	1120	130.4	1000	96.1	0.86	6	1.1	2	46	7000
MCHT1250F6-500	1250	145.4	1000	96.2	0.86	5.9	1.1	2	48	7170
MCHT1400F6-500	1400	162.7	1000	96.3	0.86	5.9	1.1	1.9	51	7360
MCHT1600F6-560	1600	183.6	1000	96.4	0.87	4.9	0.9	1.8	97	8300
MCHT1800F6-560	1800	206.3	1000	96.5	0.87	5.2	0.9	1.8	101	8550
MCHT2000F6-560	2000	229	1000	96.6	0.87	5.7	1	1.9	106	8780

Motor Type	Rated Power	Current	Sync Speed	Efficiency	Power Factor	Locked Current	Locked Torque	Maximum Torque	Moment of inertia	Weight
	kW	A	r/min	$\eta\%$	$\cos \phi$	Rated Current	Rated Torque	Rated Torque	J kgm2	kg
MCHT132F8-315	132	18.1	750	93.8	0.75	5.6	0.9	2.4	4.5	3050
MCHT160F8-315	160	21.6	750	93.9	0.76	5.1	1.1	2.1	5.3	3130
MCHT185F8-315	185	24.9	750	94	0.76	5.1	1.1	2.1	6	3200
MCHT200F8-355	200	26.2	750	94.1	0.78	5.4	1.2	2.4	6.8	3270
MCHT220F8-355	220	28.8	750	94.3	0.78	5.3	1.2	2.4	7.5	3350
MCHT250F8-355	250	32.3	750	94.4	0.79	4.9	1.1	2.2	8.2	3430
MCHT280F8-355	280	36.1	750	94.5	0.79	4.8	1	2.1	9.1	3510
MCHT315F8-400	315	39.6	750	94.6	0.81	4.9	0.9	2.1	13	4020
MCHT355F8-400	355	44.5	750	94.7	0.81	4.7	0.9	1.9	14	4090
MCHT400F8-400	400	50.1	750	94.8	0.81	4.6	0.9	1.9	15	4200
MCHT450F8-400	450	56.3	750	94.9	0.81	4.6	0.9	1.9	16	4310
MCHT500F8-450	500	61.7	750	95.1	0.82	4.6	0.9	2	19	5100
MCHT560F8-450	560	69	750	95.2	0.82	4.9	1	2	21	5300
MCHT630F8-450	630	77.5	750	95.4	0.82	5.2	1.1	2.1	23	5500
MCHT710F8-450	710	87.2	750	95.5	0.82	5.8	1.3	2.3	25	5700
MCHT800F8-500	800	97	750	95.6	0.83	5.4	1.1	2.1	44	6800
MCHT900F8-500	900	109	750	95.7	0.83	5.3	1	2.1	46	6950
MCHT1000F8-500	1000	121	750	95.8	0.83	5.3	1	2.1	48	7190
MCHT1120F8-500	1120	135.4	750	95.9	0.83	5.2	1	2	51	7320
MCHT1250F8-560	1250	151	750	96	0.83	5.1	0.9	2	120	8400
MCHT1400F8-560	1400	168.9	750	96.1	0.83	5.4	1	2	128	8600
MCHT1600F8-560	1600	192.8	750	96.2	0.83	5.6	1	2.1	134	8800

10kV -IP55 3000RPM/2P

Motor Type	Rated Power	Current	Sync Speed	Efficiency	Power Factor	Locked Current	Locked Torque	Maximum Torque	Weight
	kW	A	r/min	$\eta\%$	$\cos \phi$	Rated Current	Rated Torque	Rated Torque	kg
MCHT630T2-450	630	44	3000	95	0.87	7	0.7	2	5200
MCHT710T2-450	710	49	3000	95.1	0.88	7	0.7	2	5300
MCHT800T2-450	800	55.1	3000	95.3	0.88	7	0.7	2	5500
MCHT900T2-450	900	61.9	3000	95.4	0.88	7	0.7	2	5600
MCHT1000T2-500	1000	66.8	3000	96.1	0.9	6.8	0.7	2	6200
MCHT1120T2-500	1120	73.9	3000	96.2	0.91	6.8	0.7	2	6300
MCHT1250T2-500	1250	82.4	3000	96.3	0.91	6.6	0.7	2	6450
MCHT1400T2-560	1400	92.1	3000	96.4	0.91	6.8	0.7	2	7500
MCHT1600T2-560	1600	105.2	3000	96.5	0.91	6.8	0.7	2	7800

10kV -IP55 1500RPM/4P

Motor Type	Rated Power	Current	Sync Speed	Efficiency	Power Factor	Locked Current	Locked Torque	Maximum Torque	Weight
	kW	A	r/min	$\eta\%$	$\cos \phi$	Rated Current	Rated Torque	Rated Torque	kg
MCHT630T4-450	630	44.4	1500	95.2	0.86	6.5	0.8	2	5400
MCHT710T4-450	710	50.1	1500	95.4	0.86	6.5	0.8	2	5500
MCHT800T4-450	800	55.6	1500	95.5	0.87	6.5	0.8	2	5700
MCHT900T4-450	900	62.5	1500	95.6	0.88	6.5	0.8	2	5800
MCHT1000T4-500	1000	68.6	1500	95.7	0.88	6.5	0.8	2	6400
MCHT1120T4-500	1120	76.7	1500	95.8	0.88	6.5	0.8	2	6500
MCHT1250T4-500	1250	85.4	1500	96	0.88	6.5	0.8	2	6650
MCHT1400T4-560	1400	94.5	1500	96.1	0.89	6.5	0.8	2	7700
MCHT1600T4-560	1600	107.9	1500	96.2	0.89	6.5	0.8	2	8000

10kV -IP55 1000RPM/6P

Motor Type	Rated Power	Current	Sync Speed	Efficiency	Power Factor	Locked Current	Locked Torque	Maximum Torque	Weight
	kW	A	r/min	$\eta\%$	$\cos \phi$	Rated Current	Rated Torque	Rated Torque	kg
MCHT450T6-450	450	33.2	1000	94.2	0.83	6	0.8	2	5400
MCHT500T6-450	500	36.8	1000	94.5	0.83	6	0.8	2	5500
MCHT560T6-450	560	40.7	1000	94.6	0.84	6	0.8	2	5700
MCHT630T6-450	630	45.6	1000	94.9	0.84	6	0.8	2	5800

Frame Size	Mounting Dimensions (mm)												
	A	B1	B2	B3	B4	C		Dm6		E		F	
						2P	4,6,8P	2P	4,6,8P	2P	4,6,8P	2P	4,6,8P
315	630	800	900	/	/	254		75	100	140	210	20	28
355	630	710	800	900	/	254		75	95	140	170	20	25
400	710	800	900	1000	/	280		80	110	170	210	22	28
450	800	900	1000	1120	1250	280		95	120	170	210	25	32
500	900	1250	/	/	/	425	315	110	140	210	250	28	36
560	1000	1400	/	/	/	530	355	130	160	250	300	32	40

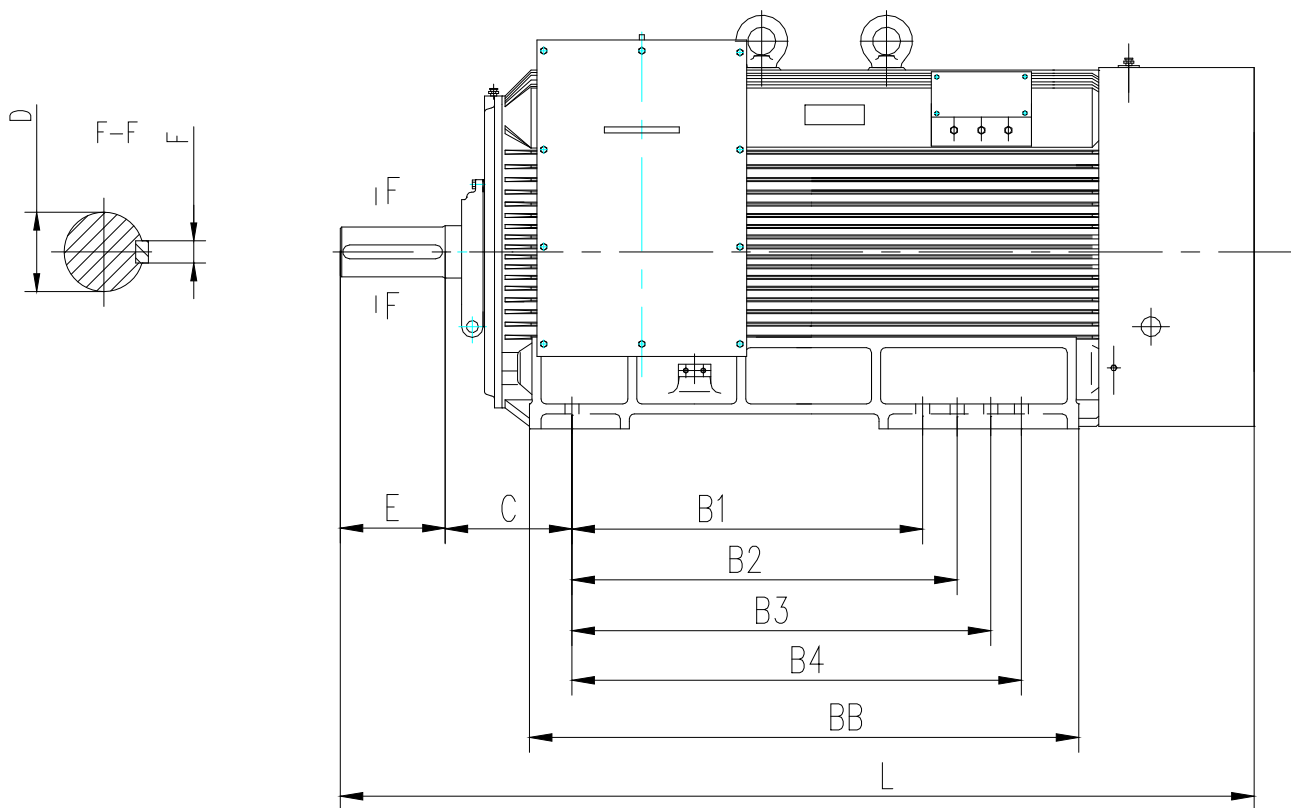

B3

		Outline Dimensions (mm)						
H	K	AB	AD	BB		HB	HD	L
				2P	4,6,8P			
315	28	730	750	1200		110	900	2000
355	35	760	860	1200		210	970	2000
400	35 x 47	870	860	1300		290	1050	2200
450	35 x 47	980	930	1495		390	1135	2360
500	42 x 60	1080	970	1600	1490	470	1220	2560
560	42 x 60	1180	1030	1680		590	1380	2660

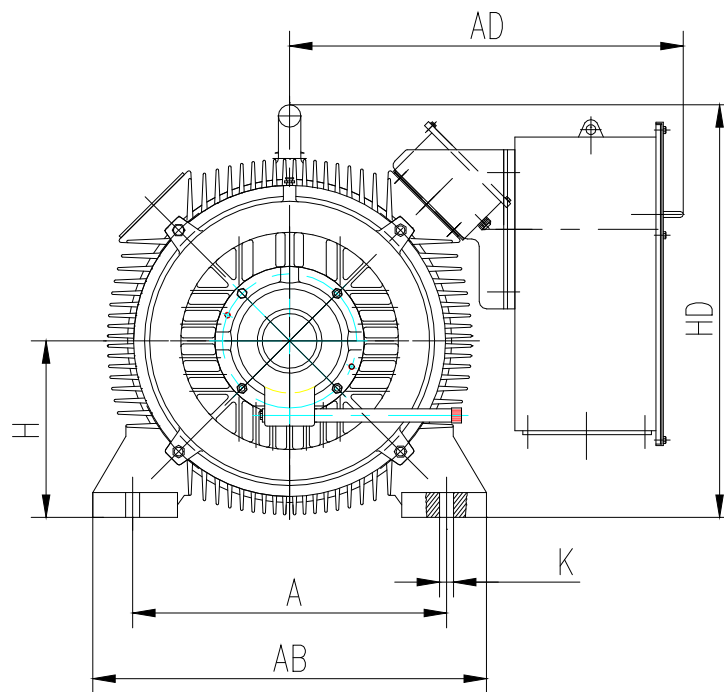

High Voltage Motors IP55

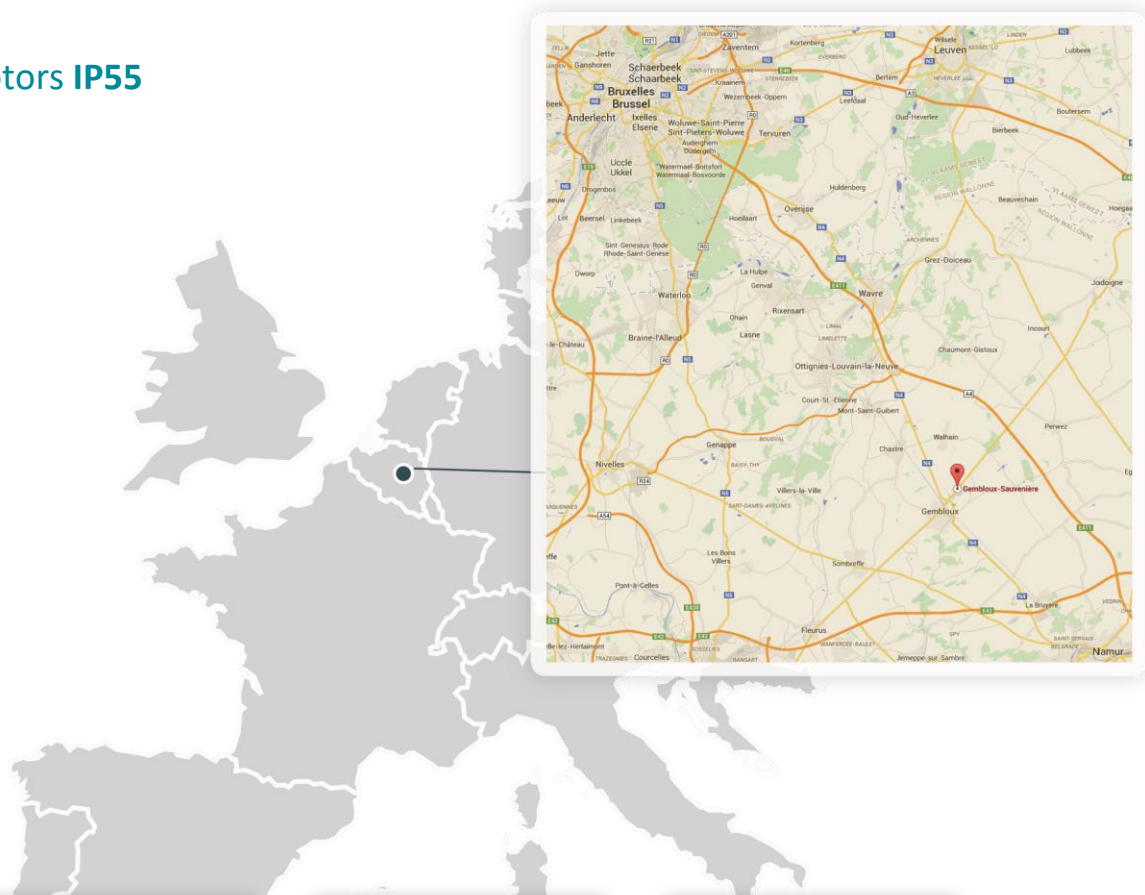

Focquet S.A.
Rue des Haïpes, 1

5030 Sauvenière (Gembloux) Belgium

Phone : +32 (0)81 625 970

Fax : +32 (0)81 625 979

Email : info@focquet.be



www.focquet.be